

**MODEL NO : DBC088HIX60L01****MODEL VERSION: 00****SPEC VERSION : V1.0****ISSUED DATE: 2019.09.18**

- Draft Specification**  
 **Final Product Specification**

**Customer : \_\_\_\_\_**

Approved by	Notes

**Confirmed :**

Prepared by	Checked by	Approved by

This technical specification is subjected to change without notice

## Table of Contents

1.0	General description .....	p.4
2.0	Absolute maximum ratings.....	p.5
3.0	Optical characteristics.....	p.6
4.0	Block diagram .....	p.10
5.0	Interface pin connection .....	p.12
6.0	Electrical characteristics .....	p.15
7.0	Reliability test items .....	p.19
8.0	Outline dimension .....	p.20
9.0	Package specification .....	p.21
10.0	General precaution .....	p.22

## Record of Revision

Rev	Issued Date	Description	Editor
1.0	2019-09-18	Initial Specification Release	

## 1.0 GENERAL DESCRIPTION

### 1.1 Introduction

Duobond model DBC088HIX60L01 is a active matrix thin film transistor (TFT) liquid crystal display (LCD) that uses amorphous silicon TFT as a switching device. This model is composed of a TFT LCD panel and a driving circuit. This TFT LCD has a 8.82 inch diagonally measured active display area with HD (768 horizontal by 768 vertical pixel ) resolution.

### 1.2 Features

- 8.82 (1:1 diagonal) inch configuration, cutted from 10.4" 1024x768
- 16.2M
- ROHS / Halogen Free Compliance

### 1.3 Applications

- Automobile

### 1.4 General information

Item		Specification	Unit
Outline Dimension		179.4 (H)x179.6(V)x11.85 (D) (Typ)	mm
Display area		158.4(H) x 158.4(V) (8.82" diagonal)	mm
Number of Pixel		768(H) x 768(V)	pixels
Pixel pitch		0.20625(H) x 0.20625(V)	mm
Pixel arrangement		RGB Vertical Stripe	
Display mode		Normally Black	
NTSC		70(Typ.)	%
Surface treatment		Antiglare, Hard-Coating (3H)	
Weight		T.B.D.	g
Back-light		N/A	
Power Consumption	Logic System (White Pattern)	Logic 2.0W(typ) TBD(max) @V <sub>DVDD</sub> =3.3V	W
	B/L System	7.5	W

## 2.0 ABSOLUTE MAXIMUM RATINGS

### 2.1 Electrical Absolute Rating

#### 2.1.1 TFT LCD Module

Item	Symbol	Min.	Max.	Unit	Note
Power supply voltage	$V_{DVDD}$	-0.3	5	V	
	$V_{DVDD\_LVDS}$				
	$V_{AVDD}$	-0.5	15	V	
	$V_{GH}$	-0.3	42	V	
	$V_{GL}$	-20	0.3	V	
	$V_{GH} - V_{GL}$	-0.3	40	V	
Logic Signal Input Level	$V_{DVDD}$ $V_{DVDD\_LVDS}$	-0.3	5	V	

### 2.2 Environment Absolute Rating

Item	Symbol	Min.	Max.	Unit	Note
Operating Temperature	$T_{opa}$	-20	70	°C	
Storage Temperature	$T_{stg}$	-30	80	°C	

### 3.0 OPTICAL CHARACTERISTICS

#### 3.1 Optical specification

Item	Symbol	Condition	Min.	Typ.	Max.	Unit	Note
Contrast	CR		600	900	—		(1)(2)
Response time	Rising	TR+TF	—	30	40	msec	(1)(3)
	Falling						
Color chromaticity (CIE1931)	White	$W_x$	$\Theta=0$ Normal viewing angle	0.273	0.313	0.353	(1)(4)
		$W_y$		0.289	0.329	0.369	
	Red	$R_x$			TBD		
		$R_y$			TBD		
	Green	$G_x$			TBD		
		$G_y$			TBD		
	Blue	$B_x$			TBD		
		$B_y$			TBD		
Viewing angle	Hor.	$\Theta_L$	CR>10	80	85	—	
		$\Theta_R$		80	85	—	
	Ver.	$\Theta_U$		80	85	—	
		$\Theta_D$		80	85	—	
Brightness uniformity	$B_{UNI}$	$\Theta=0$	70	80	—	%	(5)
Optima View Direction	Free						(6)

#### 3.2 Measuring Condition

- Measuring surrounding : dark room
- LED current  $I_L$  240mA
- Ambient temperature :  $25\pm 2^\circ\text{C}$
- 15min. warm-up time.

### 3.3 Measuring Equipment

- FPM520 of Westar Display technologies, INC., which utilized SR-3 for Chromaticity and BM-5A for other optical characteristics.

- Measuring spot size : 20 ~ 21 mm

**Note (1)** Definition of Viewing Angle:

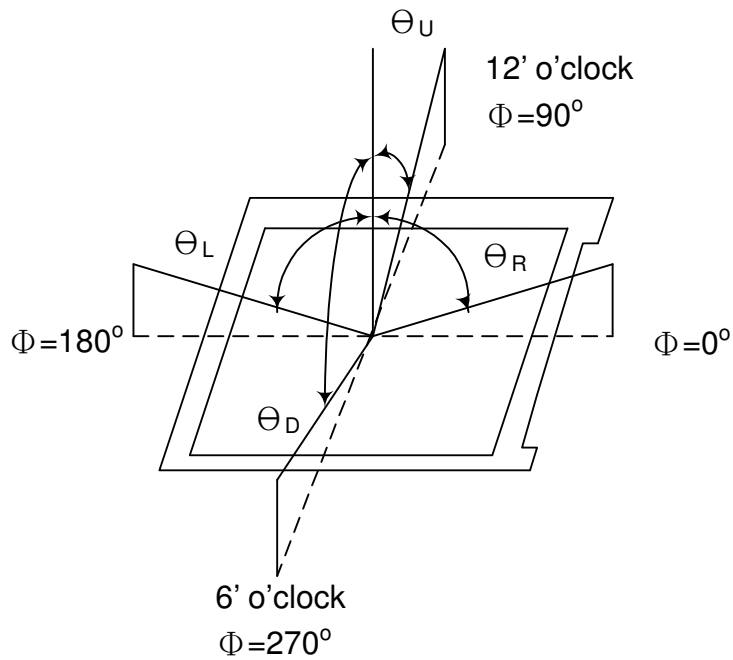

**Note (2)** Definition of Contrast Ratio (CR) :  
measured at the center point of panel

$$CR = \frac{\text{Luminance with all pixels white}}{\text{Luminance with all pixels black}}$$

**Note (3)** Definition of Response Time : Sum of  $T_R$  and  $T_F$

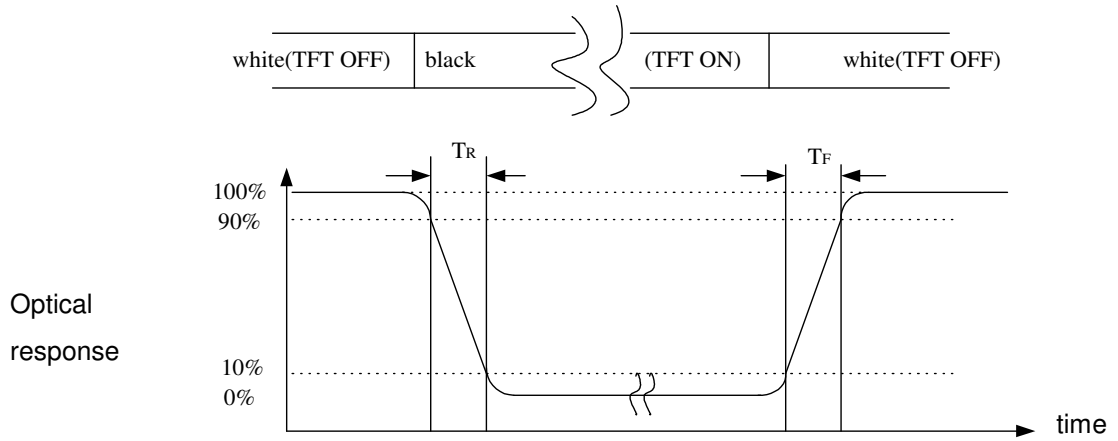

**Note (4)** Definition of optical measurement setup

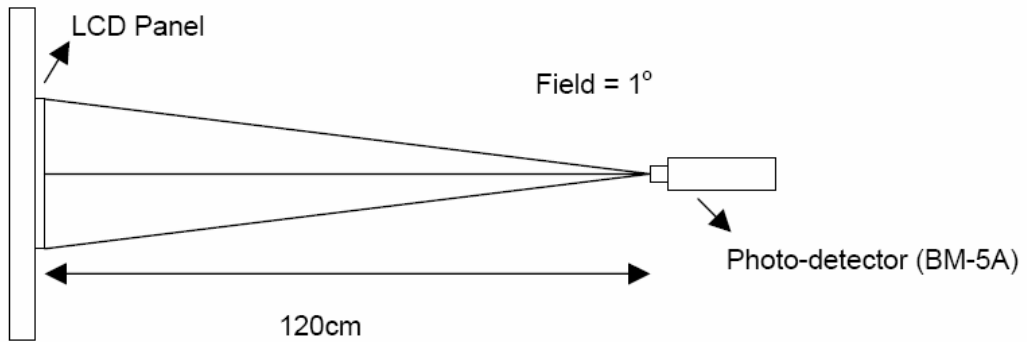



**Note (5)** Definition of brightness uniformity

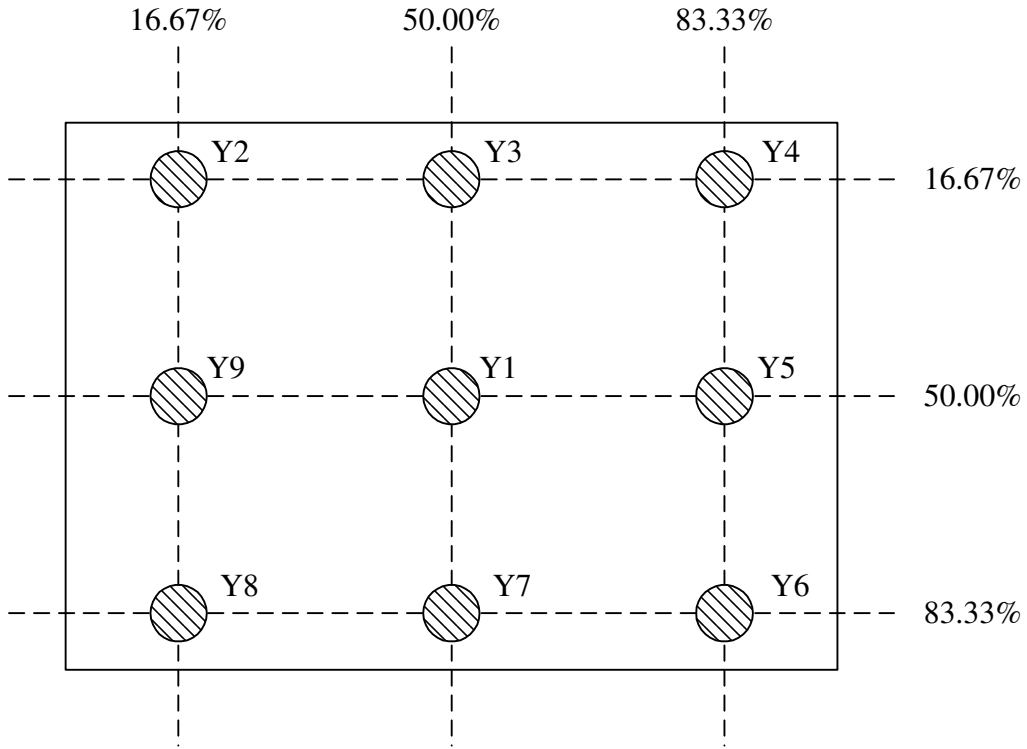

$$\text{Luminance uniformity} = \frac{(\text{Min Luminance of 9 points})}{(\text{Max Luminance of 9 points})} \times 100\%$$

**Note (6)** : Rubbing Direction (The different Rubbing Direction will cause the different optima view direction.)

## 4.0 BLOCK DIAGRAM

### 4.1 TFT LCD Module:

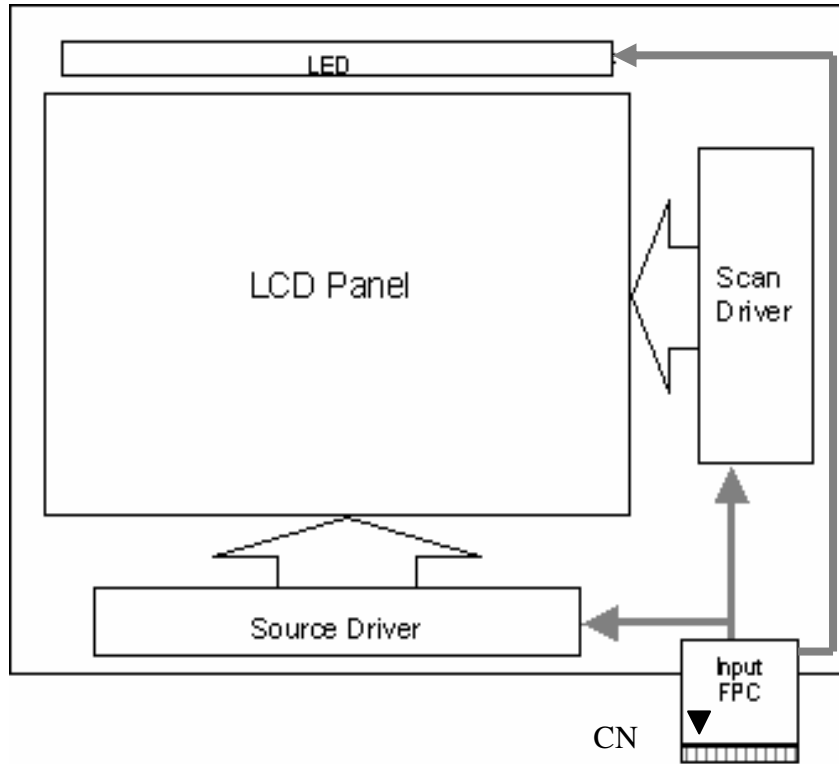

### 4.2 Pixel Format

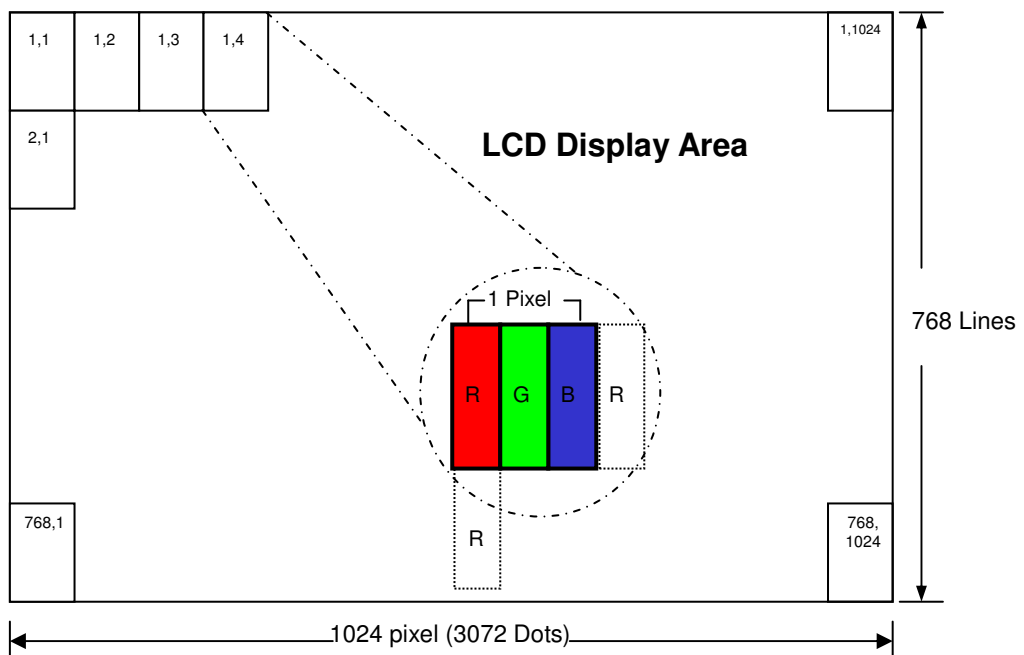

### 4.3 Relationship Between Displayed Color and Input

	Display	MSB								LSB								Gray scale Level								
		R7	R6	R5	R4	R3	R2	R1	R0	G7	G6	G5	G4	G3	G2	G1	G0		B7	B6	B5	B4	B3	B2	B1	B0
Basic color	Black	L	L	L	L	L	L	L	L	L	L	L	L	L	L	L	L	L	L	L	L	L	L	L	L	-
	Blue	L	L	L	L	L	L	L	L	L	L	L	L	L	L	L	L	H	H	H	H	H	H	H	H	-
	Green	L	L	L	L	L	L	L	L	H	H	H	H	H	H	H	H	L	L	L	L	L	L	L	L	-
	Light Blue	L	L	L	L	L	L	L	L	H	H	H	H	H	H	H	H	H	H	H	H	H	H	H	H	-
	Red	H	H	H	H	H	H	H	H	L	L	L	L	L	L	L	L	L	L	L	L	L	L	L	L	-
	Purple	H	H	H	H	H	H	H	H	L	L	L	L	L	L	L	L	H	H	H	H	H	H	H	H	-
	Yellow	H	H	H	H	H	H	H	H	H	H	H	H	H	H	H	H	L	L	L	L	L	L	L	L	-
	White	H	H	H	H	H	H	H	H	H	H	H	H	H	H	H	H	H	H	H	H	H	H	H	H	-
Gray scale of Red	Black	L	L	L	L	L	L	L	L	L	L	L	L	L	L	L	L	L	L	L	L	L	L	L	L	L0
	Dark ↑	L	L	L	L	L	L	L	H	L	L	L	L	L	L	L	L	L	L	L	L	L	L	L	L	L1
		L	L	L	L	L	L	H	L	L	L	L	L	L	L	L	L	L	L	L	L	L	L	L	L	L2
		:	:	:	L3...L251																					
	↓ Light	H	H	H	H	H	H	L	L	L	L	L	L	L	L	L	L	L	L	L	L	L	L	L	L	L252
		H	H	H	H	H	H	H	L	H	L	L	L	L	L	L	L	L	L	L	L	L	L	L	L	L
	H	H	H	H	H	H	H	L	L	L	L	L	L	L	L	L	L	L	L	L	L	L	L	L	L254	
Red	H	H	H	H	H	H	H	H	L	L	L	L	L	L	L	L	L	L	L	L	L	L	L	L	Red L255	
Gray scale of Green	Black	L	L	L	L	L	L	L	L	L	L	L	L	L	L	L	L	L	L	L	L	L	L	L	L	L0
	Dark ↑	L	L	L	L	L	L	L	L	L	L	L	L	L	L	H	L	L	L	L	L	L	L	L	L	L1
		L	L	L	L	L	L	L	L	L	L	L	L	L	H	L	L	L	L	L	L	L	L	L	L	L2
		:	:	:	L3...L251																					
	↓ Light	L	L	L	L	L	L	L	L	H	H	H	H	H	L	L	L	L	L	L	L	L	L	L	L252	
		L	L	L	L	L	L	L	L	H	H	H	H	H	H	L	H	L	L	L	L	L	L	L	L	L253
	L	L	L	L	L	L	L	L	H	H	H	H	H	H	L	L	L	L	L	L	L	L	L	L254		
Green	L	L	L	L	L	L	L	L	H	H	H	H	H	H	H	L	L	L	L	L	L	L	L	Green L255		
Gray scale of Blue	Black	L	L	L	L	L	L	L	L	L	L	L	L	L	L	L	L	L	L	L	L	L	L	L	L	L0
	Dark ↑	L	L	L	L	L	L	L	L	L	L	L	L	L	L	L	L	L	L	L	L	L	L	L	H	L1
		L	L	L	L	L	L	L	L	L	L	L	L	L	L	L	L	L	L	L	L	L	H	L	L	L2
		:	:	:	L3...L251																					
	↓ Light	L	L	L	L	L	L	L	L	L	L	L	L	L	L	L	L	H	H	H	H	H	L	L	L	L252
		L	L	L	L	L	L	L	L	L	L	L	L	L	L	L	L	H	H	H	H	H	L	H	L	L253
	L	L	L	L	L	L	L	L	L	L	L	L	L	L	L	L	H	H	H	H	H	H	L	L	L254	
Blue	L	L	L	L	L	L	L	L	L	L	L	L	L	L	L	L	H	H	H	H	H	H	H	H	Blue L255	
Gray scale of White & Black	Black	L	L	L	L	L	L	L	L	L	L	L	L	L	L	L	L	L	L	L	L	L	L	L	L	L0
	Dark ↑	L	L	L	L	L	L	L	H	L	L	L	L	L	L	H	L	L	L	L	L	L	H	L	L1	
		L	L	L	L	L	L	H	L	L	L	L	L	L	H	L	L	L	L	L	L	H	L	L	L2	
		:	:	:	L3...L251																					
	↓ Light	H	H	H	H	H	H	L	L	H	H	H	H	H	L	L	H	H	H	H	H	L	L	L	L252	
		H	H	H	H	H	H	L	H	H	H	H	H	H	L	H	H	H	H	H	H	L	H	L	L253	
	H	H	H	H	H	H	H	L	H	H	H	H	H	H	L	H	H	H	H	H	H	L	L	L254		
White	H	H	H	H	H	H	H	H	H	H	H	H	H	H	H	H	H	H	H	H	H	H	H	White L255		

## 5.0 INTERFACE PIN CONNECTION

### 5.1 FPC Pin Assignment:

FPC connector is used for electronics interface. The recommended model is CN1 (Input signal): 089K60-000100-G2-R (STARCONN)

Pin NO.	Symbol	Description	Note
1	AGND	Analog ground	
2	AVDD	Analog power	
3	DVDD	Digital power	
4	GND	Digital ground	
5	VCOM	Not connect	
6	DVDD	Digital power	
7	GND	Digital ground	
8	V14	Not connect	
9	V13	Not connect	
10	V12	Not connect	
11	V11	Not connect	
12	V10	Not connect	
13	V9	Not connect	
14	V8	Not connect	
15	GND	Digital ground	
16	DVDD_LVDS	LVDS power	
17	GND	Digital ground	
18	PIND3	Positive LVDS differential data input	
19	NIND3	Negative LVDS differential data input	
20	GND	Digital ground	
21	PINC	Positive LVDS differential clock input	
22	NINC	Negative LVDS differential clock input	
23	GND	Digital ground	
24	PIND2	Positive LVDS differential data input	
25	NIND2	Negative LVDS differential data input	
26	GND	Digital ground	
27	PIND1	Positive LVDS differential data input	
28	NIND1	Negative LVDS differential data input	
29	GND	Digital ground	
30	PIND0	Positive LVDS differential data input	

Pin NO.	Symbol	Description	Note
31	NIND0	Negative LVDS differential data input	
32	GND	Digital ground	
33	GND_LVDS	LVDS ground	
34	GRB	Global reset pin. Active low to enter reset state. Suggest to connecting with an RC reset circuit for stability. Normally pull high. (R=10KΩ,C=0.1uF)	
35	STBYB	Standby mode, normally pull high STBYB= 1, normal operation STBYB=0, timing control, source driver will turn off, all output are high-Z	
36	SHLR	Left or right display control	Note 1
37	DVDD	Digital power	
38	UPDN	Up / down display control	Note 1
39	AGND	Analog ground	
40	AVDD	Analog power	
41	VCOM	Not connect	
42	DITH	Dithering function enable control. Normally pull low DITHER= "1", Enable internal dithering function DITHER= "0", Disable internal dithering function	
43	GND	Digital ground	
44	DVDD	Digital Power	
45	GND	Digital ground	
46	V7	Not connect	
47	V6	Not connect	
48	V5	Not connect	
49	V4	Not connect	
50	V3	Not connect	
51	V2	Not connect	
52	V1	Not connect	
53	GND	Digital ground	
54	DVDD	Digital power	

Pin NO.	Symbol	Description	Note
55	SELB	6bit/8bit mode select, SELB = "0", LVDS input data is 8bits SELB = "1": LVDS input data is 6bits	Note 2
56	VGH	Positive power for TFT	
57	DVDD	Digital power for Gate IC	
58	VGL	Negative power for TFT	
59	GND	Digital ground for Gate IC	
60	NC	Not connect	

**Note 1 : UPDN and SHLR control function**

UPDN	SHLR	Data shifting
0	1	Normally display
0	0	Inverse Left and Right
1	1	Inverse Up and Down
1	0	Inverse Left and Right Inverse Up and Down

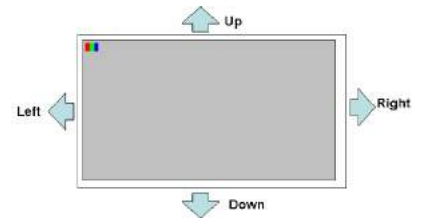

**Note 2 : If LVDS input data is 6 bits, SELB must be set to High  
If LVDS input data is 8 bits, SELB must be set to Low  
DITH and SELB control function**

DITH	SELB	Data shifting
0	1	Colors (262K)
0	0	Colors (262K)
1	1	Colors (262K)
1	0	Colors (16.2M)

## 6.0 ELECTRICAL CHARACTERISTICS

### 6.1 TFT LCD Module

Item	Symbol	Min.	Typ.	Max.	Unit	Note
Supply Voltage	$V_{DVDD}$	3	3.3	3.6	V	
	$V_{DVDD\_LVDS}$					
	VGH		23		V	Note (1)
	VGL		-10		V	Note (2)
	AVDD		12.1		V	
	VCOM	5.18	5.48	5.78	V	Note (3)
Input signal voltage	$V_{iH}$	0.8 VDD		VDD	V	
	$V_{iL}$	0		0.2VDD	V	
Current of power supply	IDD	TBD	TBD	TBD	mA	VDD =3.3V/ Note (4)
	Iavdd	TBD	TBD	TBD	mA	AVDD=11.9V/ Note (4)
	Ivgh	TBD	TBD	TBD	mA	VGH=23V/ Note (4)
	Ivgl	TBD	TBD	TBD	mA	VGL=-10V/ Note (4)
	Ivcom	TBD	TBD	TBD	mA	VCOM=5.275V/ Note (4)

Note :

- (1) : VGH is TFT Gate operating Voltage.
- (2) : VGL is TFT Gate operating Voltage.
- (3) : VCOM must be adjusted to optimize display quality \_ Flicker Pattern ◦
- (4) : @ White Pattern & 60Hz ◦

### 6.2 Switching Characteristics for LVDS Receiver

Item	Symbol	Min.	Typ.	Max.	Unit	Conditions
Differential Input High Threshold	$V_{th}$			100	mV	$V_{CM}=1.2V$
Differential Input Low Threshold	$V_{tl}$	-100			mV	
Input Current	$I_{IN}$	-10		10	uA	
Differential input Voltage	$ V_{ID} $	0.1		0.6	V	
Common Mode Voltage Offset	$V_{CM}$	0.7	1.2	1.6	V	

### 6.3 Bit LVDS input

#### 6.3.1 6bit LVDS input

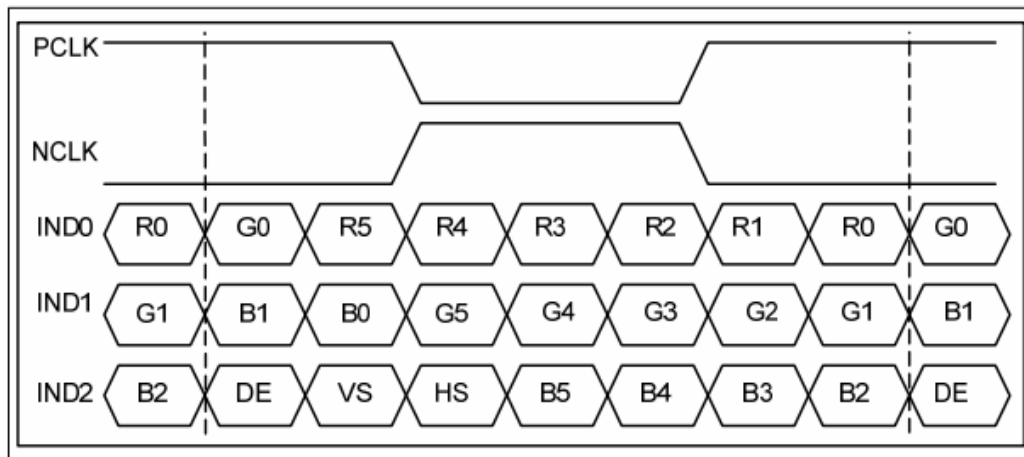

#### 6.3.2 8Bit LVDS input

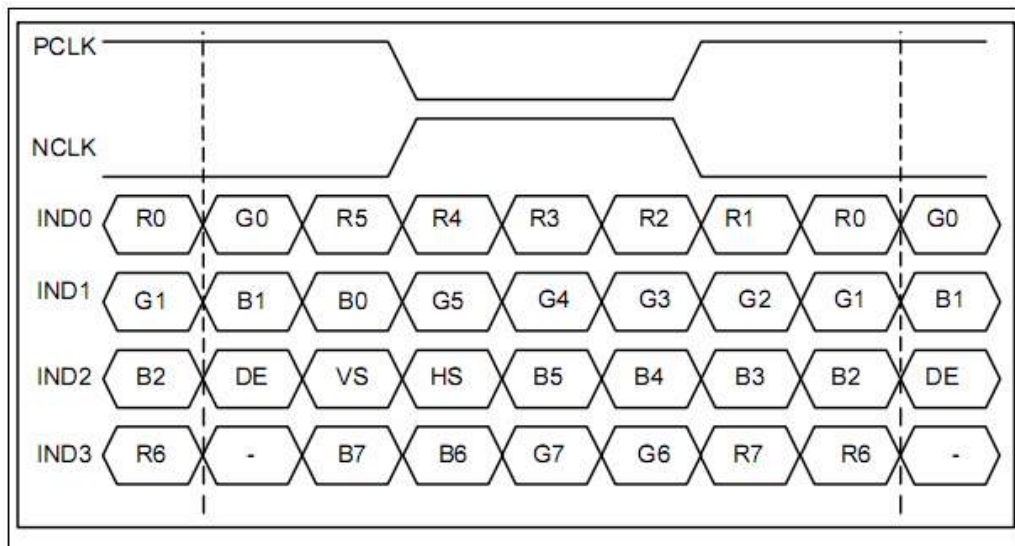



### 6.4 Interface Timing (DE mode)

DE mode					
Parameter	Symbol	Value			Unit
		Min.	Typ.	Max.	
DCLK frequency @Frame rate=60hz	fclk	52	65	71	Mhz
Horizontal display area	thd	1024			DCLK
HSYNC period time	th	1114	1344	1400	DCLK
HSYNC blanking	thb+thfp	90	320	376	DCLK
Vertical display area	tvd	768			H
VSYNC period time	tv	778	806	845	H
VSYNC blanking	tvb+tvfp	10	38	77	H

#### Timing Diagram of Interface Signal (DE mode)

##### (1). Vertical input timing

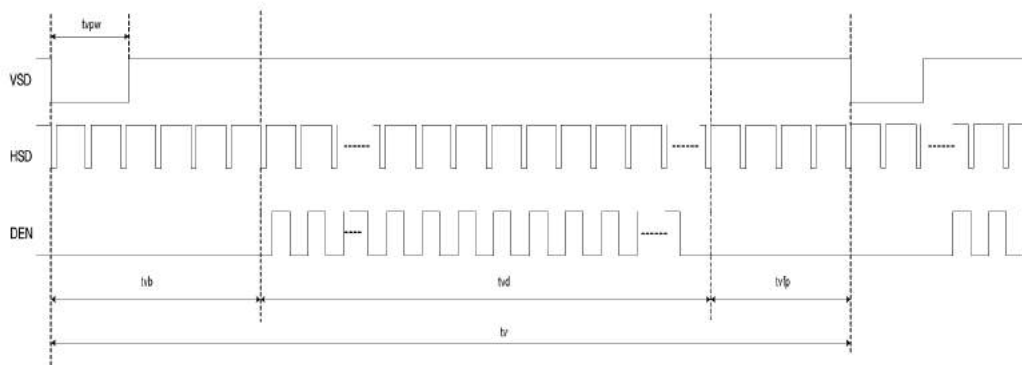

##### (2). Horizontal input timing

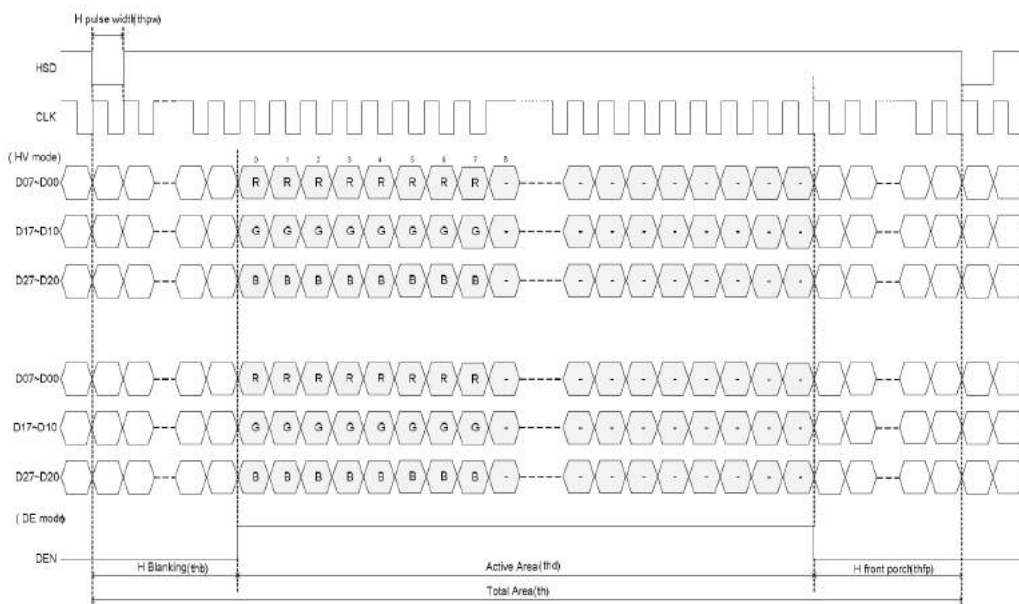

### 6.5 Power On / Off Sequence

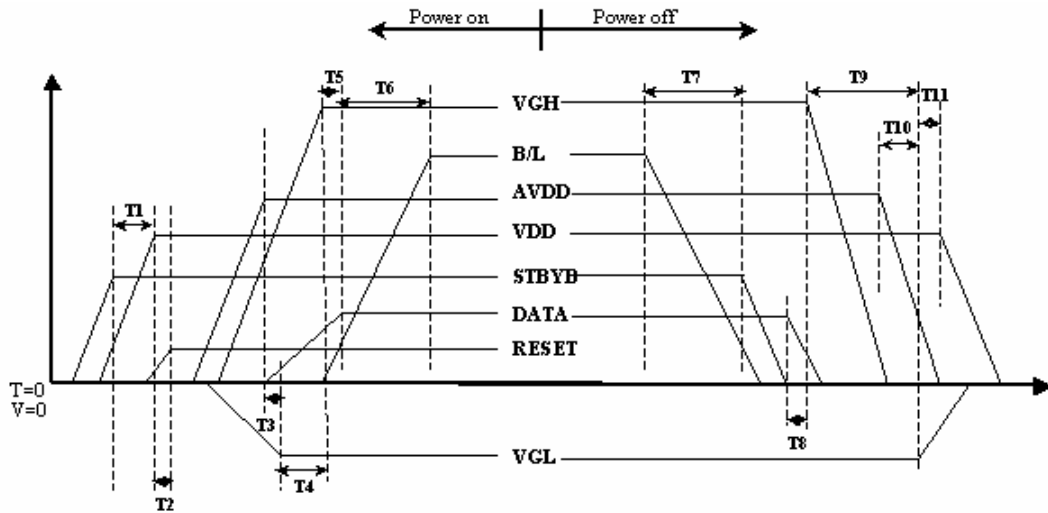

Item	Min.	Typ.	Max.	Unit
T1	0	--	--	ms
T2	50	--	--	ms
T3	5	--	--	ms
T4	10	--	--	ms
T5	20	--	--	ms
T6	50	--	--	ms
T7	20	--	--	ms
T8	10	--	--	ms
T9	20	--	--	ms
T10	10	--	--	ms
T11	20	--	--	ms

## 7.0 Reliability test items

No.	Item	Conditions	Remark
1	High Temperature Storage	Ta=+80°C, 240hrs	
2	Low Temperature Storage	Ta=-30°C, 240hrs	
3	High Temperature Operation	Ta=+70°C, 240hrs	
4	Low Temperature Operation	Ta=-20°C, 240hrs	
5	High Temperature and High Humidity (operation)	Ta=+60°C, 90%RH, 240hrs	
6	Thermal Cycling Test (non operation)	-30°C(30min) → +80°C(30min), 200 cycles	
7	Electrostatic Discharge	±200V,200pF(0Ω) 1 time/connector	
8	Vibration	1.Random: 1.04G, 10~500Hz, XYZ, 30min/each direction 2.Sine: Freq.1.5G, 8~33.3Hz, Stoke: 1.3mmhz Sweep: 2.9G, 333.3~400 X/Z: 2hrs, Y:4hrs	
9	Shock	Half-Sine, 100G, 6ms, ±XYZ, 1time	
10	Vibration (with carton)	Random: 0.015G <sup>2</sup> /Hz, 5~200Hz -6dB/Octave, 200~400Hz XYZ 各方向 2hrs	
11	Drop (with carton)	Drop height condition, basis on the product weight and follow QB100-0027 1 corner, 3 edges, 6 surfaces	

Note: There is no display function NG issue occurred, all the cosmetic specification is judged before the reliability stress.

### 8.0 OUTLINE DIMENSION

Unit : mm

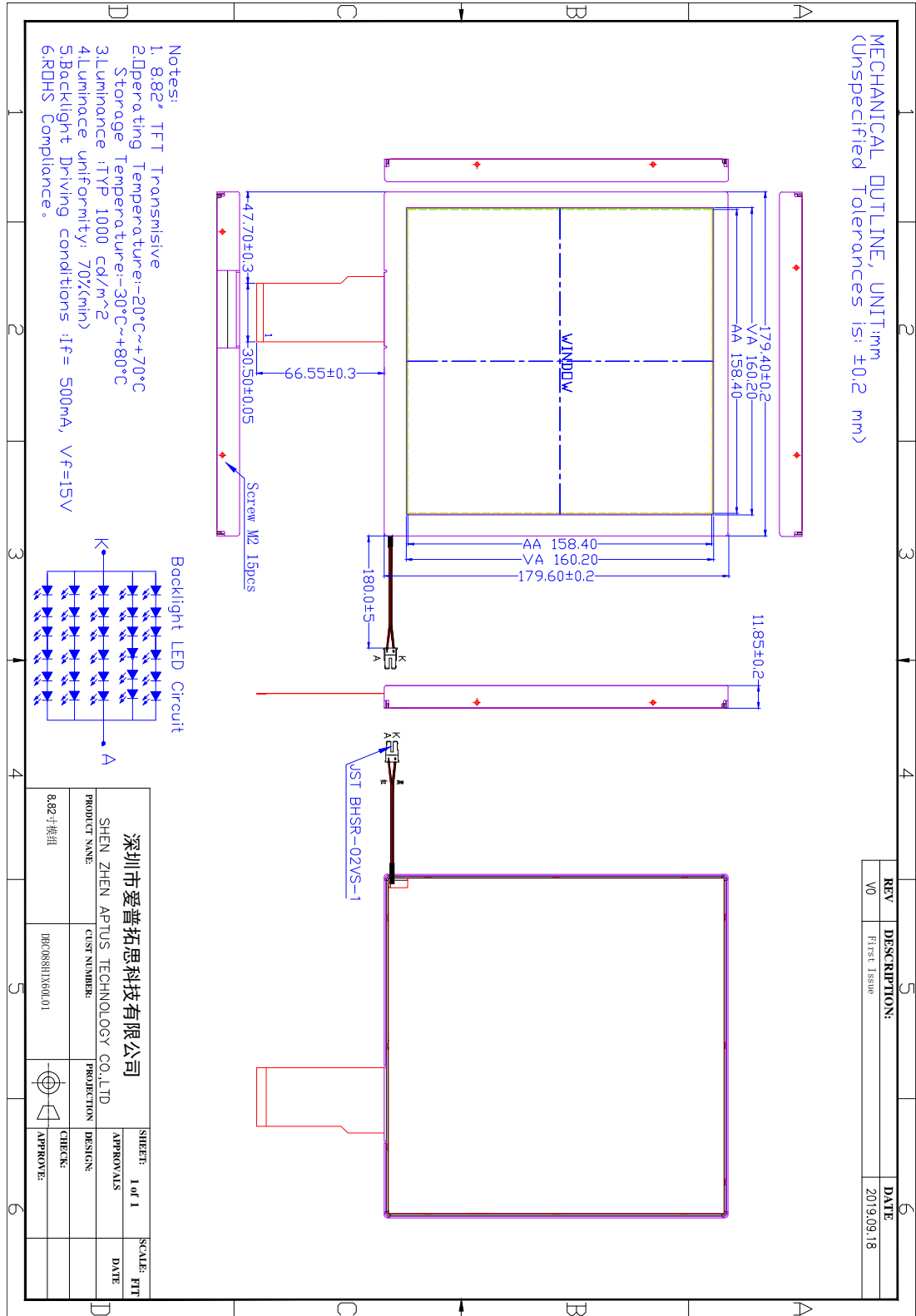

## 9.0 PACKAGE SPECIFICATION

T.B.D.

## **10.0 GENERAL PRECAUTION**

### **10.1 Use Restriction**

This product is not authorized for use in life supporting systems, aircraft navigation control systems, military systems and any other application where performance failure could be life-threatening or otherwise catastrophic.

### **10.2 Disassembling or Modification**

Do not disassemble or modify the module. It may damage sensitive parts inside LCD module, and may cause scratches or dust on the display. HannStar does not warrant the module, if customers disassemble or modify the module.

### **10.3 Breakage of LCD Panel**

10.3.1. If LCD panel is broken and liquid crystal spills out, do not ingest or inhale liquid crystal, and do not contact liquid crystal with skin.

10.3.2. If liquid crystal contacts mouth or eyes, rinse out with water immediately.

10.3.3. If liquid crystal contacts skin or cloths, wash it off immediately with alcohol and rinse thoroughly with water.

10.3.4. Handle carefully with chips of glass that may cause injury, when the glass is broken.

### **10.4 Electric Shock**

10.4.1. Disconnect power supply before handling LCD module.

10.4.2. Do not pull or fold the LED cable.

10.4.3. Do not touch the parts inside LCD modules and the fluorescent LED's connector or cables in order to prevent electric shock.

### **10.5 Absolute Maximum Ratings and Power Protection Circuit**

10.5.1. Do not exceed the absolute maximum rating values, such as the supply voltage variation, input voltage variation, variation in parts' parameters, environmental temperature, etc., otherwise LCD module may be damaged.

10.5.2. Please do not leave LCD module in the environment of high humidity and high temperature for a long time.

10.5.3. It's recommended to employ protection circuit for power supply.

### **10.6 Operation**

10.6.1 Do not touch, push or rub the polarizer with anything harder than HB pencil lead.

10.6.2 Use fingerstalls of soft gloves in order to keep clean display quality, when persons handle the LCD module for incoming inspection or assembly.

10.6.3 When the surface is dusty, please wipe gently with absorbent cotton or other soft material.

10.6.4 Wipe off saliva or water drops as soon as possible. If saliva or water drops contact with polarizer for a long time, they may causes deformation or color fading.

10.6.5 When cleaning the adhesives, please use absorbent cotton wetted with a little petroleum benzine or other adequate solvent.

### **10.7 Mechanism**

Please mount LCD module by using mounting holes arranged in four corners tightly.

### **10.8 Static Electricity**

10.8.1 Protection film must remove very slowly from the surface of LCD module to prevent from electrostatic occurrence.

10.8.2 Because LCD module use CMOS-IC on circuit board and TFT-LCD panel, it is very weak to electrostatic discharge. Please be careful with electrostatic discharge. Persons who handle the module should be grounded through adequate methods.

### **10.9 Strong Light Exposure**

The module shall not be exposed under strong light such as direct sunlight. Otherwise, display characteristics may be changed.

### **10.10 Disposal**

When disposing LCD module, obey the local environmental regulations.